

Transmission

Special Tool(s)

 ST1636-A	Retainer, Torque Converter 307-346 (T97T-7902-A)
---	---

All vehicles

NOTE: When the battery has been disconnected and reconnected, some abnormal drive symptoms can occur while the vehicle relearns its adaptive strategy. The customer needs to be notified that they can experience slightly different upshifts (either soft or firm) and that this is a temporary condition and will eventually return to normal operating condition.

NOTE: If transmission disassembly or installation of a new transmission is necessary, drain the transmission fluid. Install the transmission fluid pan drain plug when finished.

NOTE: If the transmission is to be removed for an extended period of time, support the engine with a safety stand and a wood block.

1. With the vehicle in NEUTRAL, position it on a hoist. For additional information, refer to [Section 100-02](#).
2. Disconnect the battery ground cable. For additional information, refer to [Section 414-01](#).
3. Remove the catalytic converter. For additional information, refer to [Section 309-00](#).
4. Remove the driveshaft. For additional information, refer to [Section 205-01](#).
5. Remove the Heated Oxygen Sensor (HO2S) connector from the front of the transmission fluid pan rail.

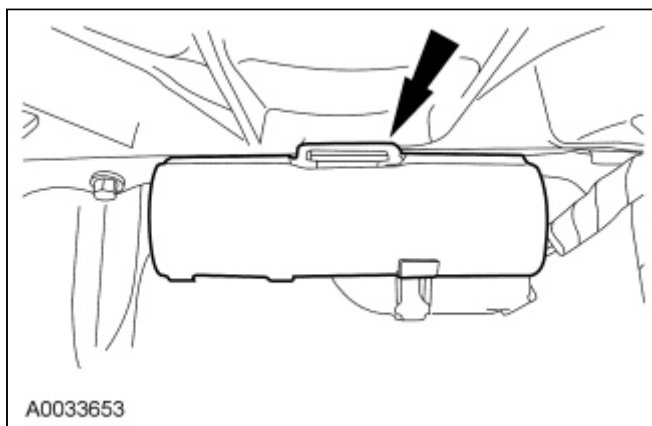

6. Remove the transmission crossmember. For additional information, refer to [Section 502-00](#).
7. Remove the selector lever cable from the transmission manual control lever.

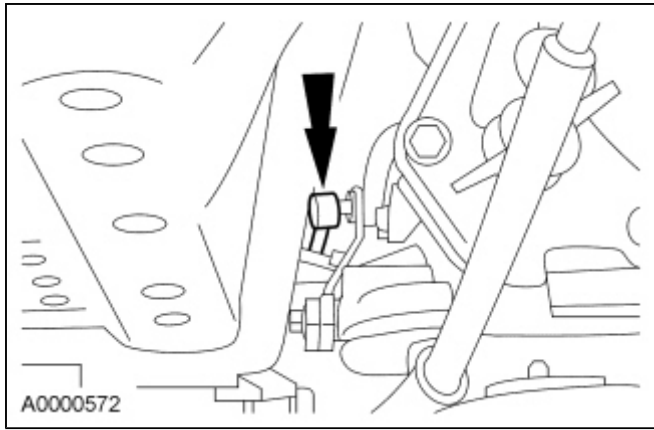

8. Remove the 2 transmission selector lever cable bracket bolts from the transmission and remove the bracket.

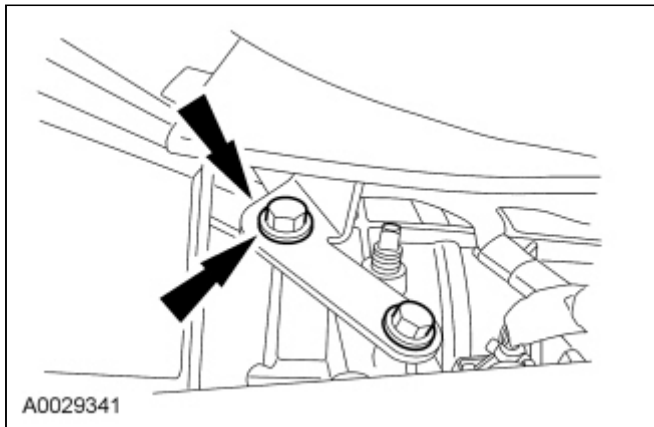

4.6L engine

9. Remove the starter. For additional information, refer to [Section 303-06](#).
10. Remove the flexplate cover.

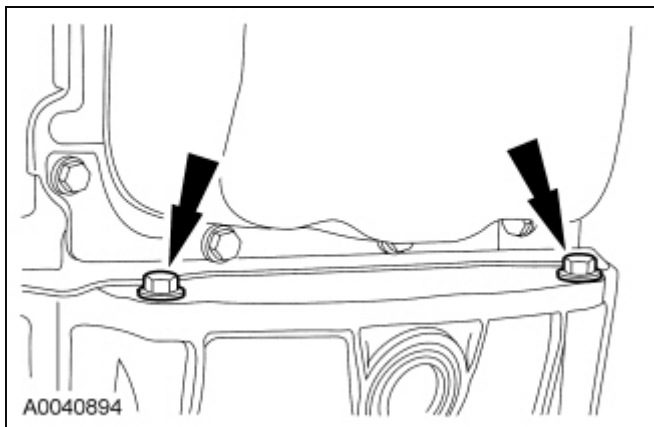

11. Remove the access cover.

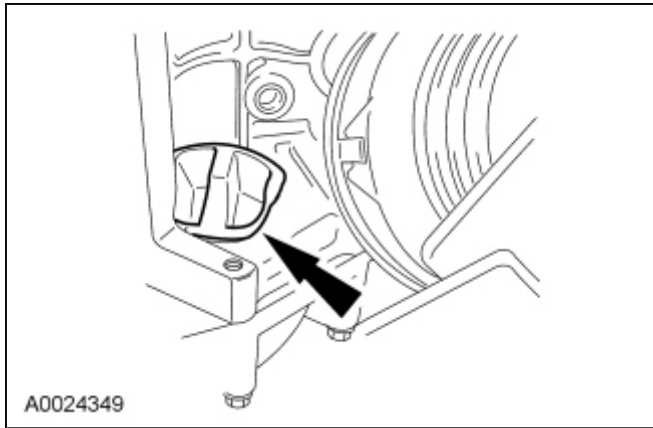

12. Remove and discard the 4 torque converter nuts.

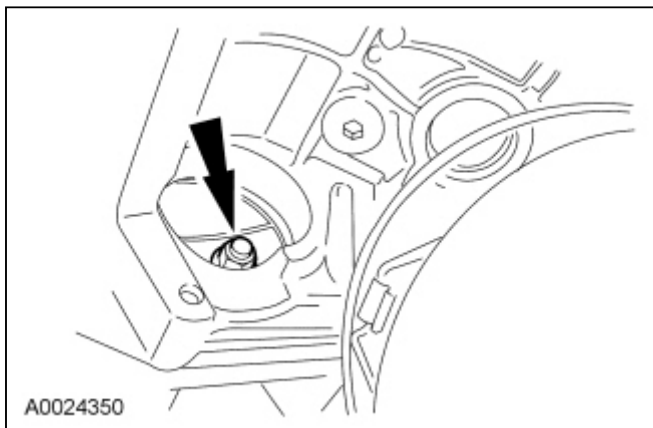

4.0L engine

13. Remove the starter and position aside.

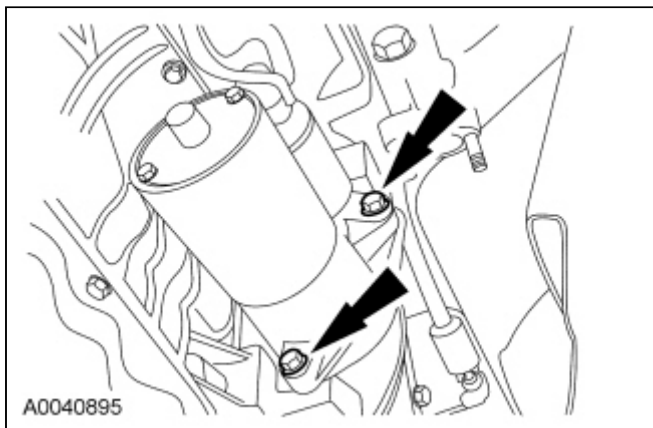

14. **NOTICE:** Rotating the crankshaft pulley bolt counterclockwise could cause a reduction in clamp load on the crankshaft pulley and timing sprocket, which could cause severe engine damage.

Remove and discard the 4 torque converter nuts.

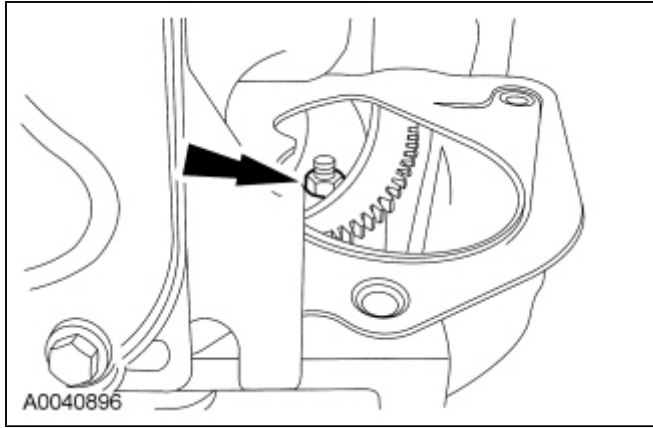

15. Remove the lower transmission retaining bolts.

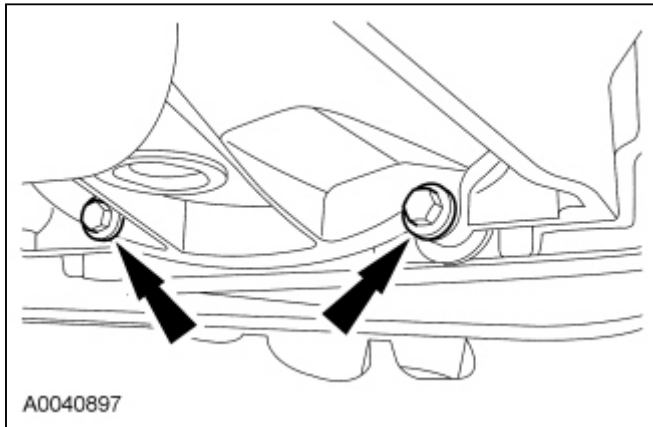

All vehicles

16. Lower the transmission to gain access to the sensor connectors and the transmission bolts.
17. Disconnect the Turbine Shaft Speed (TSS) sensor, Output Shaft Speed (OSS) sensor and intermediate shaft speed sensor connectors.

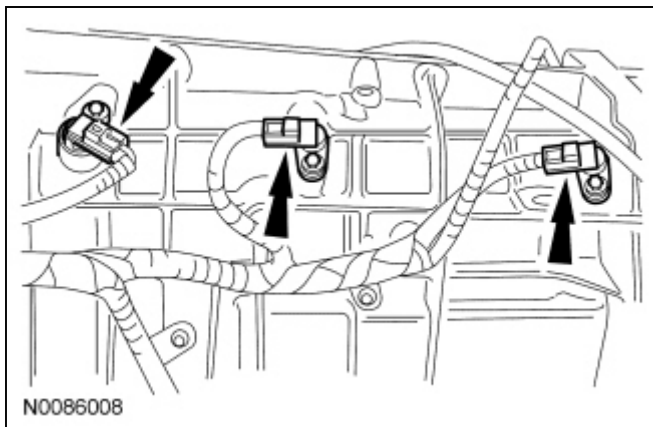

18. Disconnect the transmission vehicle harness retainers.

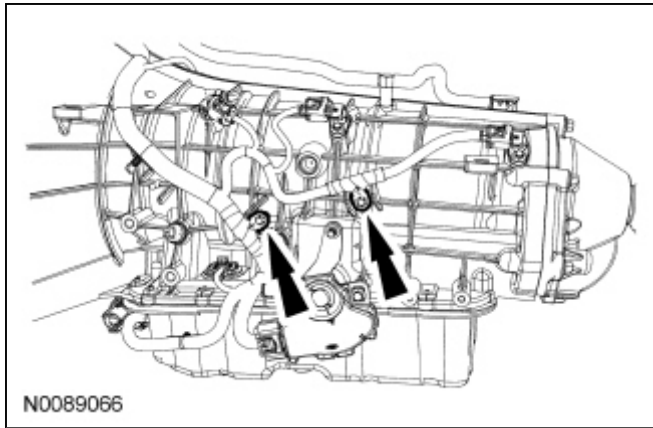

19. Disconnect the Transmission Range (TR) sensor connector.

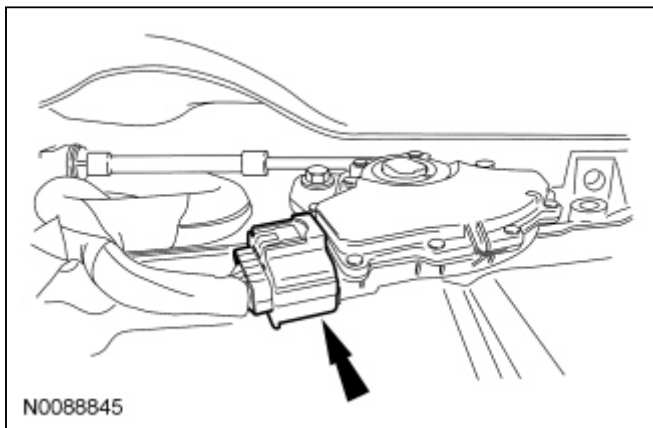

20. **NOTE:** Clean the area around the connector to prevent contamination of the transmission control solenoid body connector.

Remove the screw from the transmission vehicle harness connector and disconnect the connector.

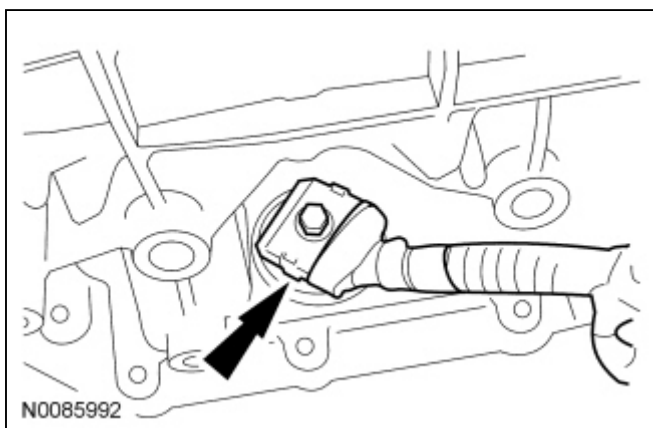

21. **NOTICE:** Do not damage the cooler tubes.

Remove the transmission fluid cooler tubes.

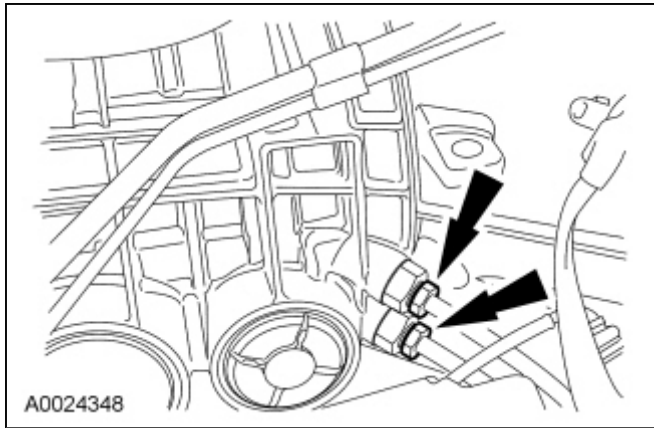

22. Remove the cooler line bracket to engine nut and position aside the transmission fluid cooler tube assembly bracket.

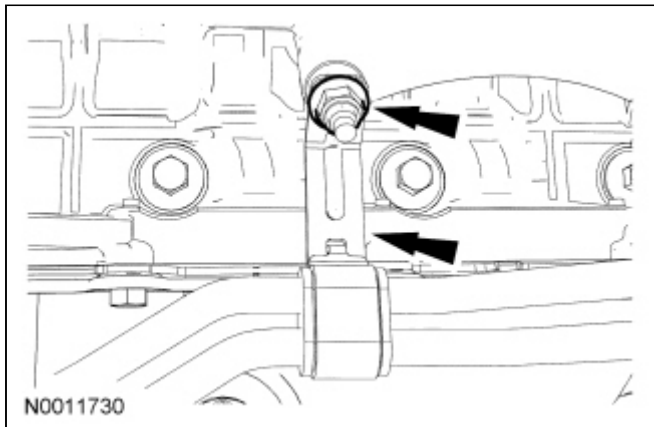

4.6L engine

23. Remove the 7 engine-to-transmission retaining bolts.

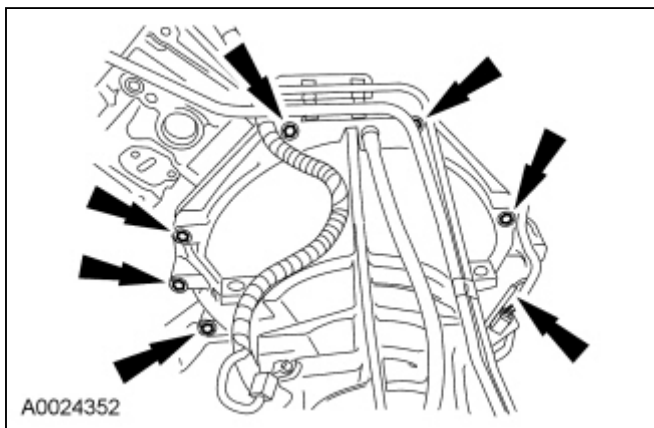

4.0L engine

24. Remove the 6 engine-to-transmission retaining bolts and position the fuel line bracket aside.

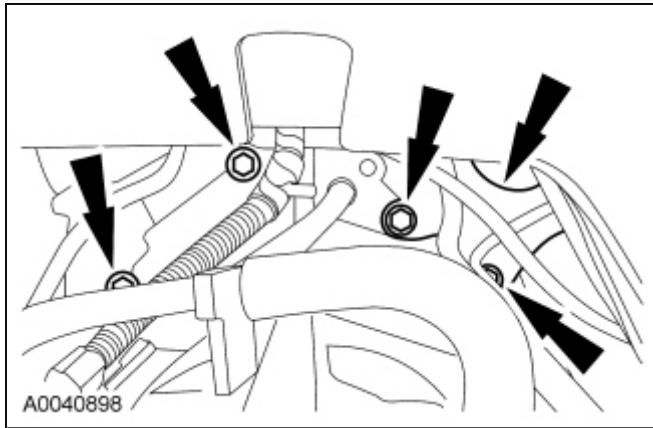

All vehicles

25. Lower the transmission assembly from the vehicle.
26. Install the Torque Converter Retainer.

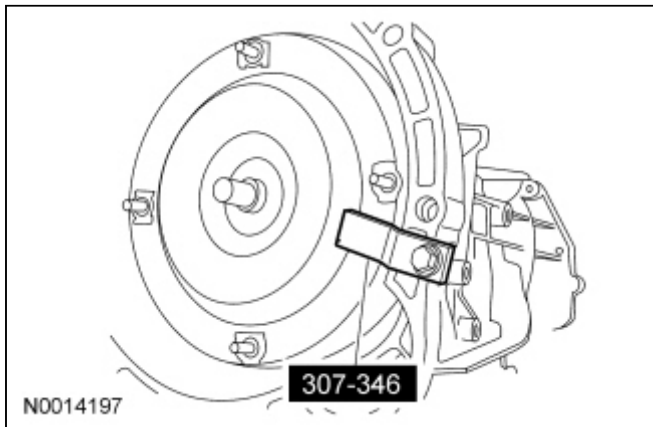

27. If the transmission is being disassembled to install new parts, or if a new or remanufactured transmission is being installed, the transmission fluid cooler, the auxiliary transmission fluid cooler (if equipped) and the transmission fluid cooler tubes must be cleaned and backflushed to keep contaminants from entering the transmission. For additional information, refer to [Transmission Fluid Cooler Backflushing and Cleaning](#) in this section.
-

